

### BENCH TEST

1. Jumper terminal 1 to terminal 2. Set both potentiometers to the CCW position. Connect a 5K potentiometer as follows:  
CCW end: terminal 1  
Wiper: terminal 3  
CW end: terminal 7
2. Connect a DC voltmeter and oscilloscope to terminals 6 and 8 with terminal 8 common.
3. Apply 120V AC to terminals 9 and 10.
4. As the 5K potentiometer is rotated through its range, the output at terminal 6 should swing at least +8 volts DC. Set it for 6 volts positive. Advance the "Ripple Adjust" to the full clockwise position. The ripple should steadily decrease to almost zero.
5. Jumper terminal 4 to terminal 5. The output should drop to approximately 0.15 volts DC.
6. Advance the "Gain" potentiometer to full CW position. The output should rise to approximately 7 to 8 volts DC.
7. Repeat steps 4, 5, and 6 with the opposite polarity, using the 5K potentiometer to reverse the output polarity.

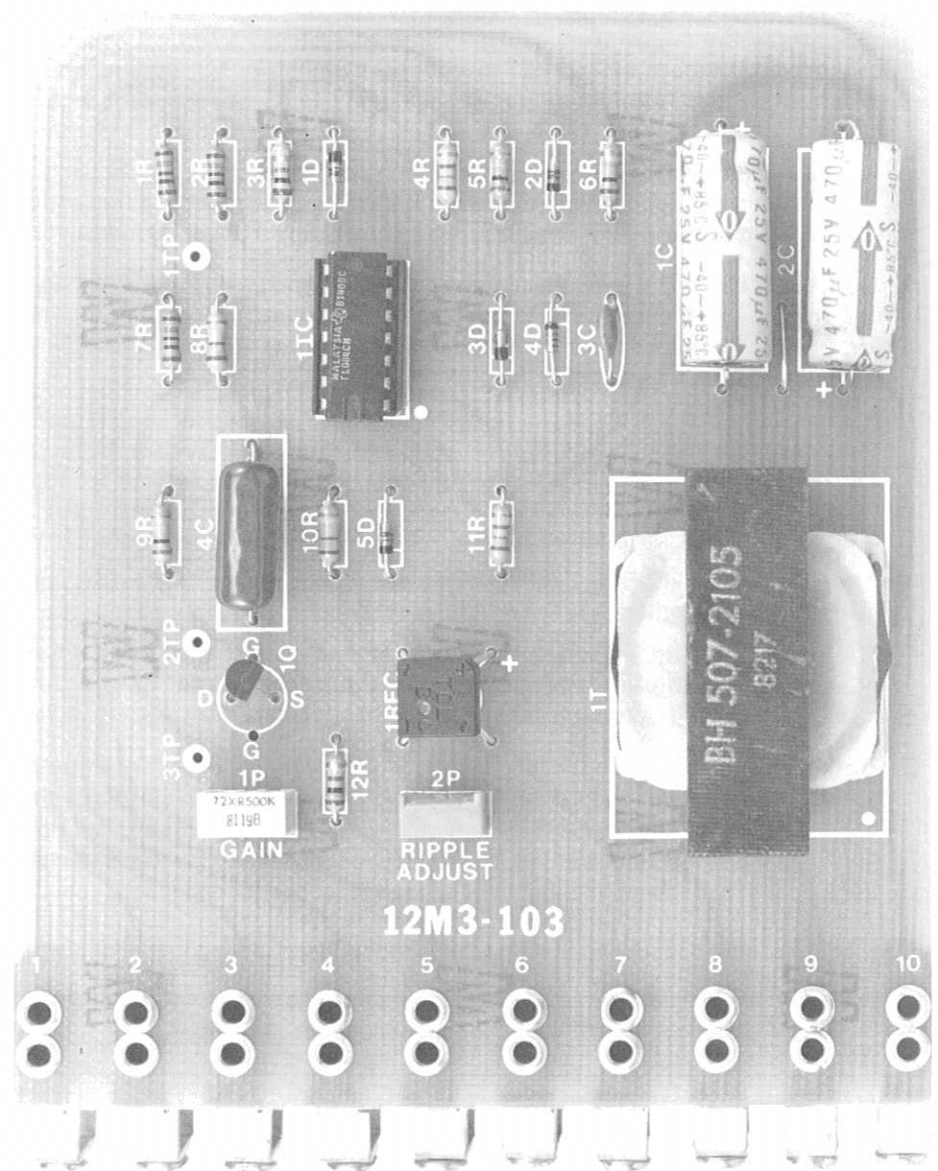

### VOLTAGE CHECKS

1. The primary voltage of 1T, leads 1 and 2 (terminals 10 and 9) should be 120V AC.
2. 10V AC nominal between terminal 7 and terminal 8, and between terminal 1 and terminal 8.
3. 20V AC nominal between terminals 1 and 7.
4. +15V DC nominal between the positive end of capacitor 1C and terminal 8 (common).
5. -15V DC nominal between the negative end of capacitor 2C and terminal 8 (common).

# REFLEX<sup>®</sup> MODEL 205 DEMODULATOR

PART NUMBER 12M03-00103

SCHEMATIC DIAGRAM 12M03-00103-01

## I. SPECIFICATIONS

### SUPPLY

- 120 Volts AC  $\pm$  10%
- 50/60 Hz, single phase

### AMBIENT TEMPERATURE

- 0° to 40°C (32° to 104°F)
- 50°C in cabinet

### INPUT

- 0.2 to 120 volts AC for 10 volts output
- 50 to 1000 Hz

### REFERENCE INPUT

- 0.2 to 250 volts AC

### OUTPUT

- Unfiltered DC,  $\pm$  13.5 volts peak @ 5 mA
- Filtered, DC,  $\pm$  10 volts nominal @ 5 mA
- An AC voltage of 20 volts at 50 mA between terminals 1 and 7 (or 10 volts between terminal 1 or 7 and circuit common, terminal 8) is available to excite a Short Stroke Reactor.

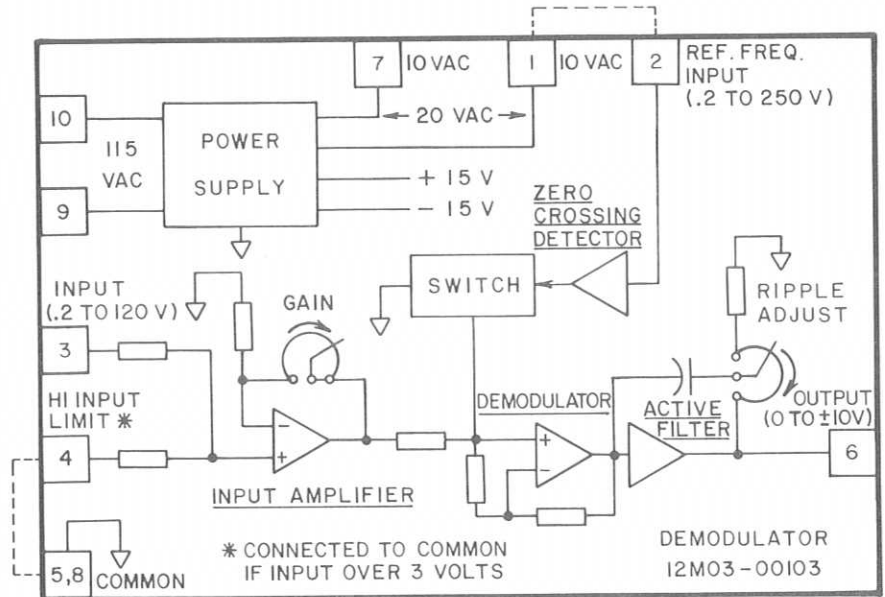

FIGURE 1 SIMPLIFIED SCHEMATIC

## II. THEORY OF OPERATION

The Model 205 Demodulator is used to convert AC signals from various transducers to a DC output whose magnitude is proportional to the magnitude of the AC signal, and whose polarity is dependent on whether the AC signal is in phase or 180° out of phase with a reference AC voltage wave.

Common transducers are LVDT's, synchros, short stroke reactors, or induction regulators.

The Demodulator consists of the following elements as shown in the Simplified Schematic Diagram (Fig. 1).

- |                           |                  |
|---------------------------|------------------|
| 1. Power Supply           | 4. Demodulator   |
| 2. Input Amplifier        | 5. Active Filter |
| 3. Zero Crossing Detector |                  |

- 1. Power Supply** – The power supply uses a center-tapped transformer with 10 volts on each side of center together with a bridge rectifier and two 470 MF filter capacitors to provide a nominal positive and negative unregulated 15 volts DC with respect to the transformer center-tap which is connected to circuit common.

Additionally, the outer legs of the transformer secondary are brought out to terminals to supply an optional 10 volt AC, 60 Hz reference for the Zero Crossing Detector, and to supply 20 volts AC excitation for transducers. 10 volts excitation is also available between common and either terminal 1 or 7.

- 2. Input Amplifier** – Op-amp 11C(B) is an AC amplifier with a gain adjustable from 1 to 50. Use of the non-inverting input provides a high input impedance for low power devices.

When used for input voltages in excess of 3 volts, a jumper between terminals 4 and 5 creates an input voltage divider of approximately 37 to 1. Clamping diodes 1D and 2D provide overvoltage protection to the input.

Its output is connected to the input of the Demodulator, 11C(C).

3. **Zero Crossing Detector** – A frequency reference voltage of 0.2V to 250V having the same frequency as that used to supply the transducer is applied to terminal 2. In the case of 60 Hz devices this reference is obtained by a jumper to terminal 1, which supplies a nominal 10 volts AC from one half of the power transformer secondary.

The AC reference voltage is applied to the input of 11C(A), acting as a comparator to determine the zero crossing of the AC reference. The output of 11C(A) is a square wave, 180° out of phase with the AC reference, and drives the gate of 1Q. FET switching transistor, 1Q, acts as open circuit between its Drain and Source when its Gate is highly negative with respect to its Source, and as a low impedance when its Gate to Source is zero.

As the AC Reference Frequency Input on terminal 2 swings positive, the output of 11C(A) swings negative and 1Q acts as an open circuit. As the AC Reference swings negative the output of 11C(A) swings positive and 1Q conducts, clamping the non-inverting input, pin 10, of Demodulator 11C(C) to circuit common.

4. **Demodulator** – Op-amp 11C(C) acts as an inverting amplifier when its input pin 10, is clamped to circuit common by the action of 1Q, and as a non-inverting amplifier when 1Q is open. It, therefore, switches alternately between non-inverting and inverting, in-phase with the AC Reference (non-inverting when reference is in the positive half cycle).

If the output of 11C(B) is in phase with the AC reference, its positive half cycle passes through 11C(C) unchanged since 11C(C) is non-inverting at this time. During the negative half of the cycle (at the output of 11C(B), amplifier 11C(C) has now been changed to inverting by the action of the AC reference, and the negative signal for 11C(B) is now inverted, and appears at the output of 11C(C) as a positive output. Thus, the output of 11C(C) is positive for both half cycles, and the signal from 11C(B) has been "demodulated."

If the output of 11C(B) is 180° out of phase with the reference AC voltage, similar action results in both half cycles being negative.

The output of 11C(C) appears as a full-wave, rectified, unfiltered sine wave with a polarity depending on the phase relationship of the transducer input compared to the reference frequency and an amplitude proportional to the magnitude of the input signal. The output is fed to the Active Filter.

5. **Active Filter** – Op-amp 11C(D) has a gain of 1 and acts as an adjustable low pass filter. As "Ripple Adjust" potentiometer 2P is turned clockwise, the output appears as increasingly pure DC. However, the response of the assembly becomes increasingly sluggish. For this reason, the ripple adjustment should be set as low as possible to allow fast system response without introducing excessive ripple.

### COMPONENT LIST - ASSEMBLY #12MO3-00103

Symbol	Part #	Description (Acceptable Substitute)*	Symbol	Part #	Description (Acceptable Substitute)*
1T	04P01-00001	Transformer - 120VAC PRI, two 10V AC SEC. @ 220 mA (Signal PC 20-220)	1, 2, 7R	01P02-10031-01	Resistor - 100K, ½W, 1%
			3R	01P01-10300-02	Resistor - 10K, ¼W, 5%
1REC	05P01-00003	Rectifier Bridge - 50V, 1A (EDI-PF50)	4R, 11R	01P01-27200-02	Resistor - 2.7K, ¼W, 5%
1D-5D	05P02-00001	Diode Signal-50 mA, 200PIV (1N4148)	5, 6, 9R	01P01-10400-02	Resistor - 100K, ¼W, 5%
1Q	05P05-00001	Transistor - N Channel JFET (2N4093)	8R, 10R	01P01-22400-02	Resistor - 220K, ¼W, 5%
11C	05P08-00002	Quad Op-Amp (TI-TL084CN)	12R	01P01-10200-02	Resistor - 1.0K, ¼W, 5%
1P	02P04-50401-00	Potentiometer - 500K, ½W (Beckman 72XR500K)			
2P	02P04-10301-00	Potentiometer - 10K, ½W (Beckman 72XR10K)			
1C, 2C	03P01-47102-01	Capacitor - 470MF, 25V, Electrolytic			
3C	03P06-10205-00	Capacitor - .001MF, 50V, Ceramic			
4C	03P07-10510-00	Capacitor - 1.0MF, 100V, Film			

\*OR EQUAL

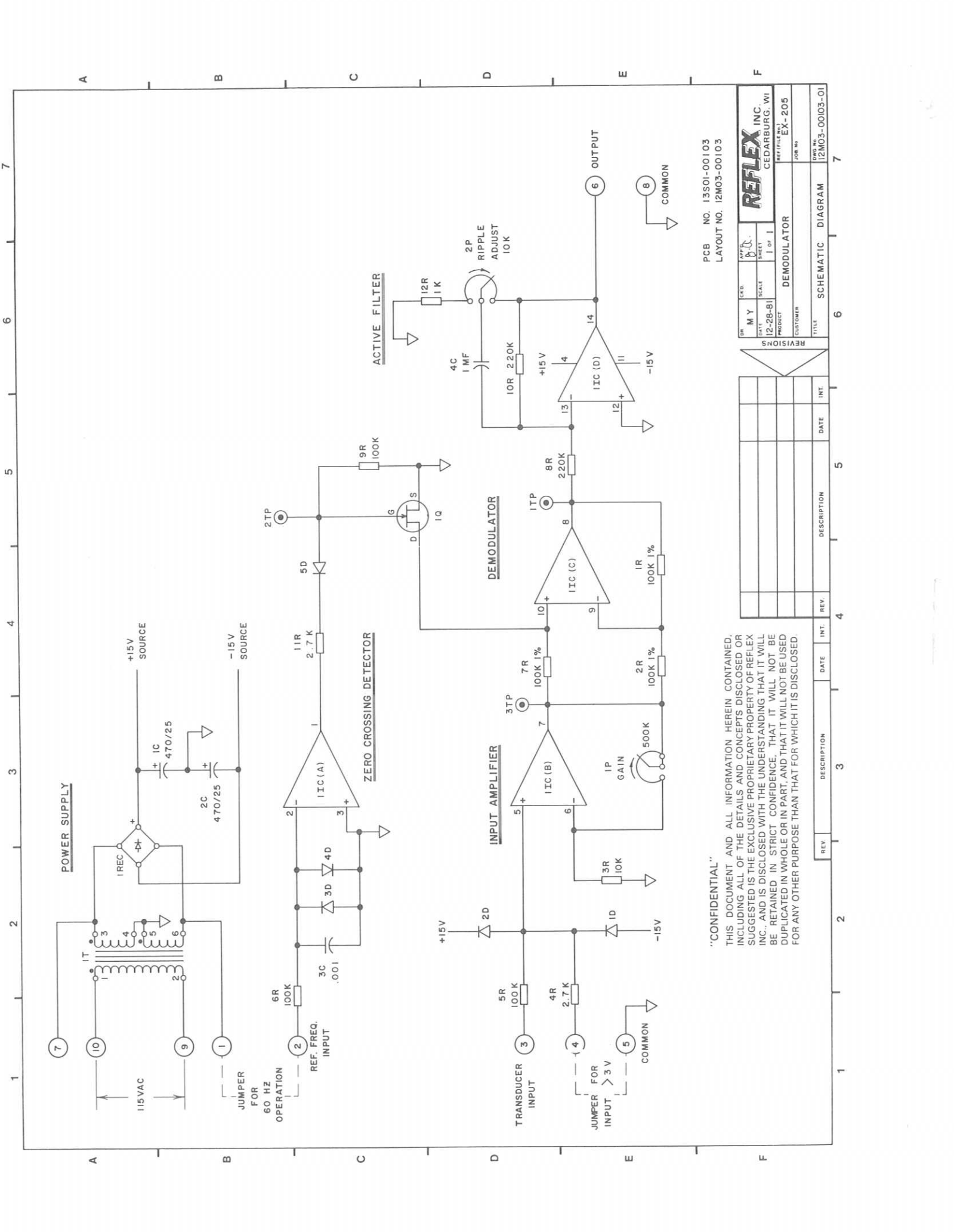

PCB NO. 13501-00103  
LAYOUT NO. 12M03-00103

REV	M Y	SCALE	SHEET	OF	1
12-28-81					
REFLEX INC.		CEDARBURG, WI		EX-205	
CUSTOMER		DEMODULATOR		JOB NO.	
TITLE		SCHEMATIC DIAGRAM		DRAWING NO. 12M03-00103-01	

"CONFIDENTIAL"  
THIS DOCUMENT AND ALL INFORMATION HEREIN CONTAINED, INCLUDING ALL OF THE DETAILS AND CONCEPTS DISCLOSED OR SUGGESTED IS THE EXCLUSIVE PROPERTY OF REFLEX INC. AND IS DISCLOSED WITH THE UNDERSTANDING THAT IT WILL BE RETAINED IN STRICT CONFIDENCE THAT IT WILL NOT BE DUPLICATED IN WHOLE OR IN PART, AND THAT IT WILL NOT BE USED FOR ANY OTHER PURPOSE THAN THAT FOR WHICH IT IS DISCLOSED.

REV	DATE	INT.	REV.	DATE	INT.	DESCRIPTION