

ML-DRIVE INSTALLATION/START-UP GUIDE

CAUTION

Hazardous Voltages. Can cause severe injury, death or damage to equipment. The ML-Drive should only be installed by a qualified electrician.

Proper earth grounding of all electronic equipment is required for successful operation. Connect a low impedance earth ground to terminal 5 of connector J2.

Separate all logic and signal level wiring (J1, J3 and J4) from all motor armature and AC power wiring (J2).

Shield all logic and signal wiring (J1, J3 and J4) and terminate to earth ground at one point only.

REQUIRED WIRING

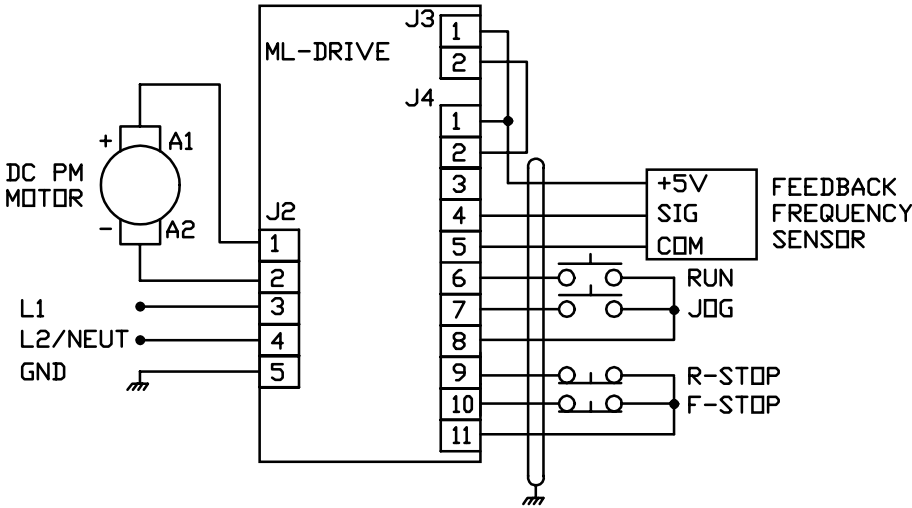

SCALING

After completing the required wiring of the ML-Drive, follow the procedure below to scale the ML-Drive for Master format RPM operation. Complete this procedure before scaling the ML-Drive for engineering units.

1. While pressing the “CLEAR” and “7” keys on the keypad, apply AC power to the ML-Drive (loads factory default parameters).
2. Enter the pulses-per-revolution of the feedback sensor into CP-31. The keypad sequence for a 60 tooth gear sensor is “Code Select”, “3”, “1”, “Enter”, “6”, “0”, “Enter”.
3. Enter the maximum system operating RPM into CP-20, and CP-34. If the feedback sensor is not directly connected to the motor shaft, enter the maximum feedback sensor shaft RPM.
4. Press the “SETPOINT” key and enter $\frac{1}{2}$ of the RPM entered in Step 3.
5. Press the RUN pushbutton.
6. Verify the motor direction is forward (exchange A1 and A2 if not forward).
7. Press the “TACH” key. Verify an RPM reading appropriate to the motor setpoint speed.
8. Press the R-Stop pushbutton.

The ML-Drive is now properly scaled in RPMs. If engineering unit setpoints and/or displays other than RPMs are desired, refer to Chapter 3 of the “ML-Drive User Manual” .

TUNING

If the drive system acts unstable or sluggish in response to setpoint or load changes, it may be necessary to tune the ML-Drive. Follow the procedure below to improve system performance:

1. Set CP-66 (Integral) and CP-67 (Derivative) to zero.
2. Reduce CP-65 (Gain) until the system goes unstable (erratic). Stability can be tested by moving between two wide spread setpoint values. When instability is reached, increase the CP-65 number slightly until the system stabilizes (larger values reduce the system gain).
3. Using only Gain, the system setpoint value may never be reached due to system losses. Reduce CP-66 (Integral) until the system becomes unstable, then increase the Integral number slightly until the system stabilizes and the desired setpoint value is reached.
4. Derivative (CP-67) is only required if the system is too sluggish after setting the Gain and Integral terms. The Derivative value, like Gain, should be reduced to the point of instability, then increased slightly until the system regains stability.

FOLLOWER OPERATION

Complete the “Scaling” and “Tuning” procedures for Master mode (Page 2) before proceeding with Follower operation. To enable Follower operation, follow the procedure below:

1. Wiring additions:

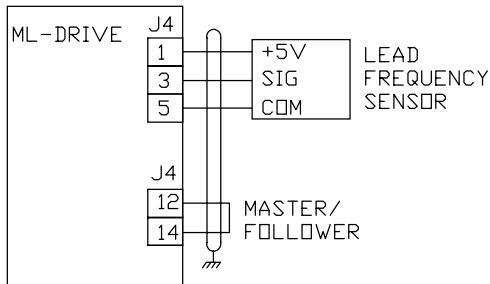

2. Enter the pulses-per-revolution of the lead (master) sensor into CP-30 (PPR Lead).
3. Enter the maximum system operating RPM of the lead motor (or sensor shaft if not directly connected to the motor) into CP-33 (Max RPM Lead).
4. The ML-Drive is now scaled for ratio follower operation. Setpoint and display values are in ratio of follower/lead. If engineering unit setpoints and/or displays other than ratio are desired, refer to Chapter 3 of the “ML-Drive User Manual”.
5. Enter the desired operating ratio into CP-3 (Follower Setpoint).

TROUBLE-SHOOTING

Master Mode: Motor Will Not Run

Step 1: Check MP-53 (Control State).

- a) Should be “0010” (Run).
- b) If not “0010”, check the Run, R-Stop and F-Stop wiring.

Step 2: Check MP-45 (Scaled Reference).

- a) Should not be zero.
- b) Press “SETPOINT” and enter a midrange value setpoint.

Step 3: Check MP-46 (Ramped Reference).

- a) Should not be zero.
- b) If MP-46 is zero, check MP-50 (Active Scaling Mode) for a value “0010” (Master Mode).
- c) If MP-50 is not “0010”, check J4 Pin 12 wiring according to Chapter 2 of the “ML-Drive User Manual”.

- Step 4: Check MP-47 (Drive Output).
- a) Should not be “0” or “100”.
 - b) If “0”, then return to step 1 of “Scaling”.
 - c) If “100”, check wiring to motor.

Step 5: If armature contactor is used, make sure it is energized.

Master Mode: Motor At Full Speed

Step 1: Press “SETPOINT” and enter midrange setpoint.

- Step 2: Check MP-43 (Feedback Frequency).
- a) Should not be zero.
 - b) Check that signal is present at feedback input (J4 Pins 4 and 5).

Step 3: Stop the ML-Drive.

- Step 4: If motor does not stop, check MP-47 (Drive Output).
- a) Should be zero.
 - b) Check MP-53: Should be “0100” or “1000”.
 - c) If not, check R-Stop and F-Stop wiring.

Step 5: If motor is still running, suspect false-fired or bad SCR’s.

Follower Mode: Motor Will Not Run

Step 1: Check unit out in Master Mode first.

- Step 2: Check MP-50 (Active Scale Mode)
- a) Should be “0100” (Follower Mode).
 - b) If not, check wiring to verify that Follower mode has been selected.

- Step 3: Check MP-53 (Control State)
- a) Should be “0010” (Run).
 - b) If not, check Run, R-Stop and F-Stop wiring.

- Step 4: Check MP-41 (Lead Frequency).
- a) Should display the lead sensor frequency.
 - b) If not, check signal at Lead Frequency input.

- Step 5: Check MP-45 (Scaled Reference).
- a) Should not be zero.
 - b) If zero, press “SETPOINT” and enter a non-zero ratio setpoint.